

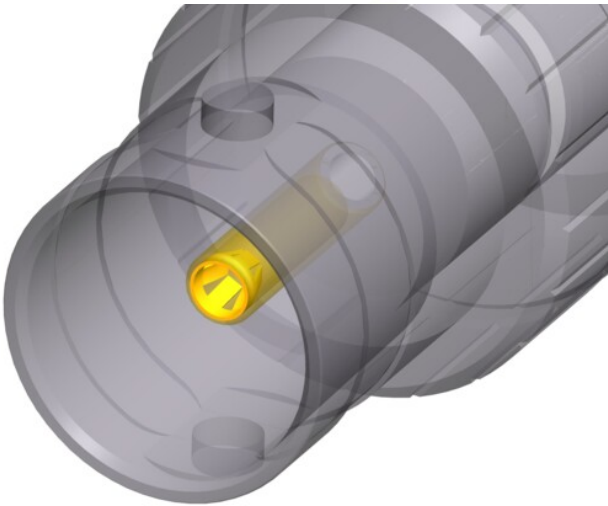

NBB75DFIB

Isolated BNC chassis connectors, feedthrough in black D-shape housing

Neutrik's BNC chassis connectors offer a true 75 Ω design for serial and digital (HD) signals. The machined brass connector body provides an extremely rugged and non-abrasive connection over long term use and is in addition recessed and therefore well protected in a D-shape housing (audio industry standard).



Features & Benefits

- Gold plated cage type center contact
- True 75 Ω design meets the stringent HD requirements
- Isolated panel mount (solves potential grounding problems and prevents common-mode influence with other connections conducted over the same panel ground potential)
- Standard D-shape housing - provides flush mounting and protection from damage
- Color coding possible

New cage type contact

- Closed contact design - extremely robust
- Gold plated cage type clip - best possible shielding and lowest contact resistance

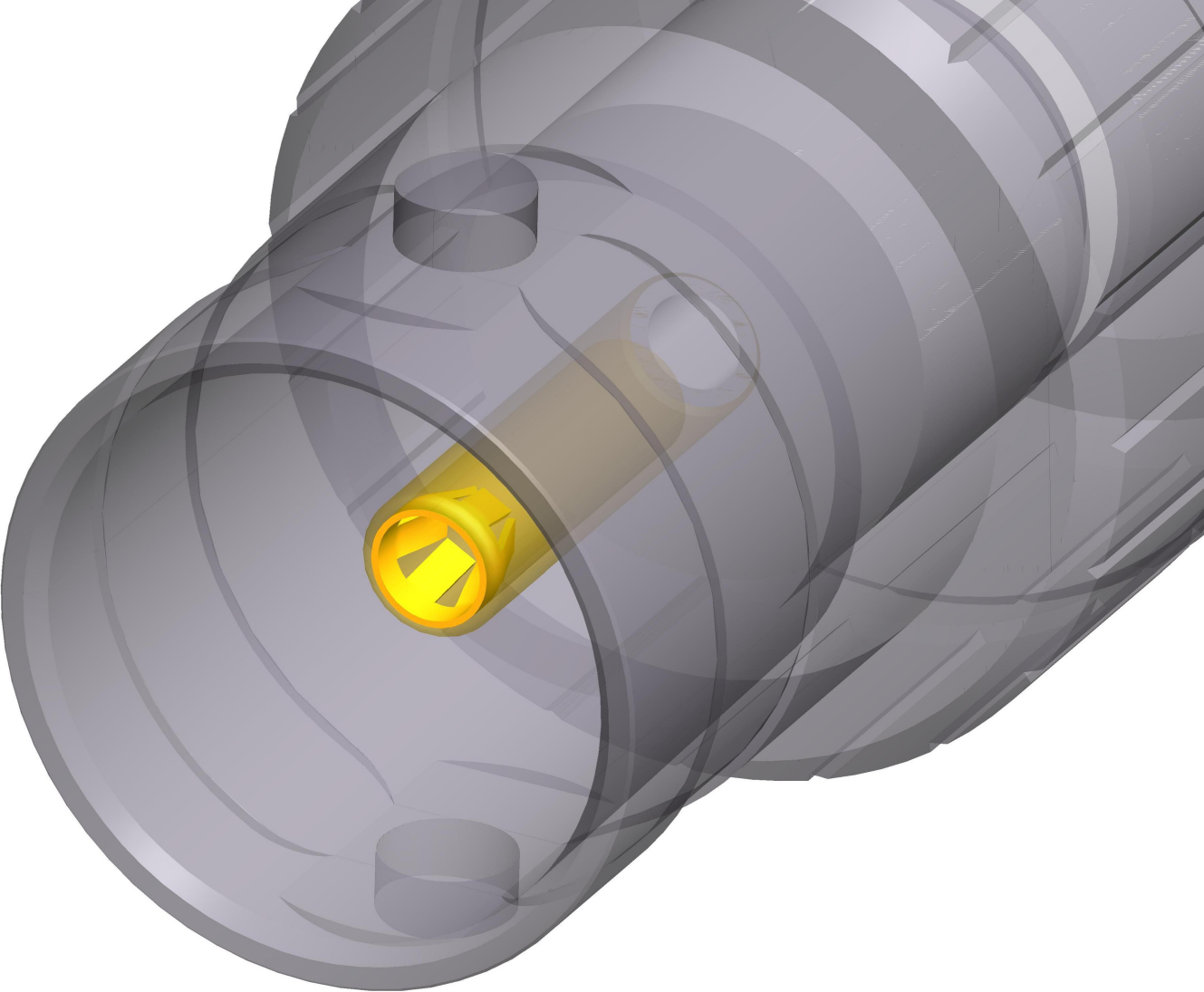

Technical Information

Product	
Title	NBB75DFIB
Connection Type	BNC 75 Ω
Gender	female

Electrical	
Signal Type	HD, SDI, Video, AES/EBU, Composit, YUV, RGB, RGBH, RGBHV
Contact resistance	≤ 3 mΩ (inner)
Contact resistance	≤ 2 mΩ (outer)
Dielectric strength	1,5 kVdc
Impedance	75 Ω
Insulation resistance	> 5 GΩ
Rated voltage	<50 V
VSWR	≤1.03/>37 dB up to 1 GHz ≤1.05/>32 dB up to 2 GHz ≤1.08/>28 dB up to 3 Ghz

Mechanical	
Insertion force	< 25 N
Lifetime	> 1000 mating cycles
Wiresize	
Locking device	Bayonett
Mounting direction	Front mounting
Chassis shape	D

Material	
Contacts	Brass (CuZn39Pb3), 0.2 µm AuCo (Center contact)
Insert	PTFE
Shell	Polyacetal (POM) (Insulation Sheell)
Shell plating	Optalloy®
D-Shape housing	Zinc diecast (ZnAl4Cu1) gal black chrome plating

Environmental	
Temperature range	-30 °C to +85 °C